

Technical Data – UV / IR² Flame Sensor

Mechanical

Housing Material:	Die Cast Zinc Alloy (ZA12)
Housing Colour:	Blue
Dimensions:	See Fig. 8
Weight:	1kg
Cable Gland Entries:	2 x 20mm

Electrical

Supply Voltage:	14 to 28Vdc
Supply Current:	See DIL switch settings
Power Up Time:	2 seconds max.
Test Signal Voltage:	14 to 28Vdc
Relay Contact Ratings:	
Current	0.25Amp. Max.
Voltage	30Vdc. Max.
Resistive Loads Only Power	3.0W Max.

Performance

Range: (See EN54-10)	0.1m ² n-heptane at 25m 0.2m ² n-heptane at 35m 0.4m ² n-heptane at 45m
Field of View:	90° min. Cone
Spectral Response:	
UV	185 to 260nm
IR	0.9 to 1.7µm
Sensitivity: (See EN54-10)	High = Class 1 Low = Class 2

Environmental

Operating Temperature:	-10°C to 85°C (14°F to 185°F)
Storage Temperature:	-20°C to 65°C (-4°F to 185°F)
Relative Humidity:	95% Non condensing
IP Rating:	IP65
EMC Immunity:	EN 50081-1, EN 50081-2 EN 50082-2, EN 50082-2 EN 50130-4, EN 55022

Mounting Bracket (Option)

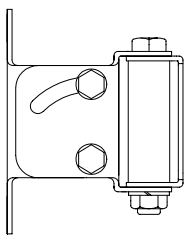

Fig. 7 Adjustable Mounting Part number: 007127

- EN54: Part 10: Flame detectors – point detectors.
- Although this sensor is not affected by normal daylight conditions, sunlight should be prevented from falling directly on to the IR optics. The immunity of the sensor to false sources will be reduced when the sensor is set to fast response times.

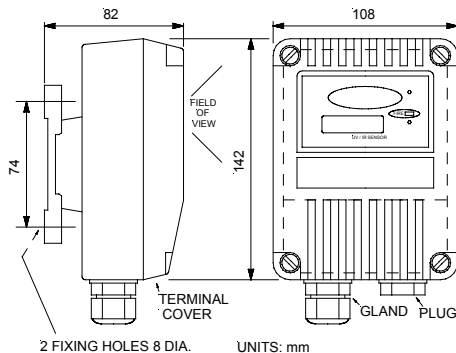

Fig. 8 Dimensions – UV / IR² Flame Sensor

Selectable Options	DIL Switch Settings	
Relay RL2 Function:	1	2
RI2 Off	0	0
UV fire or pre-alarm	1	0
IR fire or pre-alarm	0	1
Fault (Energised if OK)	1	~ 1
Alarm Current: [RL1 Flame Relay]	3	4
3/9mA RL1 Only, 4/8/14mA RL2 & RL1	0	0
4-20mA, 4/20mA, No Relays	1	0
/ Or 8-20mA, 8/20mA, & Relays	0	1
- Proportional 8/28mA, & Relays	1	~ 1
Output Mode:	5	
Non-latching (-)	0	
Latching (/)	~1	
Response Time:	6	7
Slowest ≈ 8s	0	0
Medium ≈ 4s	1	~ 0
Fast ≈ 2s	0	1
Very Fast ≈ 1s	1	1
Sensitivity:	8	
Low	0	
High	~ 1	

Factory settings ~

016291 UV / IR² FLAME SENSOR for HIGH AMBIENT TEMPERATURES

Features

- Class 1 Sensitivity to EN54-10
- 85°C (185°F) High Ambient Operating Temperature
- High Optical Interference Immunity
- Selectable Output Options
Conventional 2 wire
4-20mA
Relay Contacts; Fire/Fault, Pre-alarm
Latching or Non-latching
- Selectable Response Speed
- Remote Control Self Test
- Low Power Consumption
- CE Marked

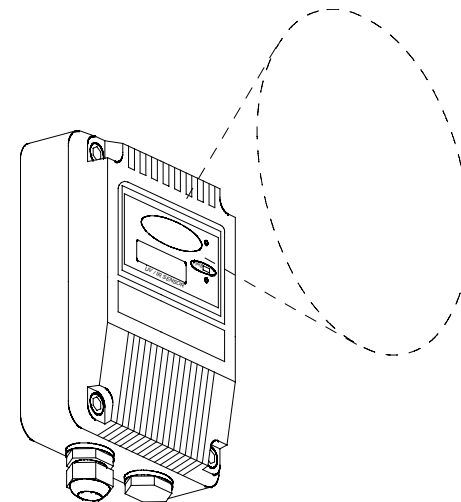

Operating Principles

The sensor responds to Ultra Violet (UV) and Infra Red (IR) flickering radiation emitted from flames during combustion.

The narrow spectral response (185 to 260nm) of the UV detector is completely insensitive to visible light, but quickly detects weak UV radiation emitted from flames. The UV detector also responds to high-voltage electrical discharges.

The dual IR detectors (IR²), respond to adjacent IR wavelengths (0.9 to 1.7µm), enable it to discriminate between flames and spurious IR sources. The IR detectors also respond to glowing embers but will ignore electrical discharges.

The combination of UV and IR² detection, plus signal processing allows the sensor to be used without risk of false alarms in difficult situations characterised by factors such as flickering blackbody radiation or arc welding.

Most other UV/IR flame sensors respond to 4.3µm IR light, emitted by hydrocarbon flames. By responding to 0.9 to 1.7µm light emitted by every fire all flickering flames can be detected. Gas fires not visible to the naked eye e.g. hydrogen may also be detected.

Electrical Connections

The sensor can be connected to a two wire circuit supplying 14V to 28V dc. The sensor is connected to the supply via terminals 1(+IN) and 2(-IN) under the front terminal cover. Connections to the sensor are polarity sensitive.

A remote sensor test input is available on terminals 3(+R) for +IN and 4(-R) 0V. When a 14V to 28V dc supply is applied to this input UV and IR test sources activate within the sensor and a flame detected state on the outputs. See Fig. 1

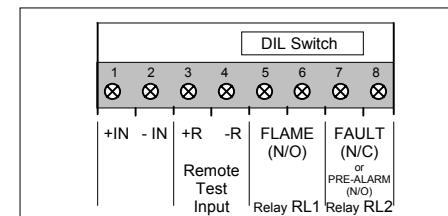

Fig. 1 Connection Terminals (Front Cover Removed)

Flame Detection Characteristics

The sensor responds to varying sizes of flame at given distances. The further away the flame is from the sensor the larger the fire has to be, with detection beyond 50m becoming unpredictable. An n-heptane flame with a base area of 0.1m² will be detected on the sensor centre line at 25m, with the sensitivity set high for class 1 performance. See Fig. 2

If the sensitivity switch were set to low, for class 3 performance, the same 0.1m² flame would be detected at 12m.

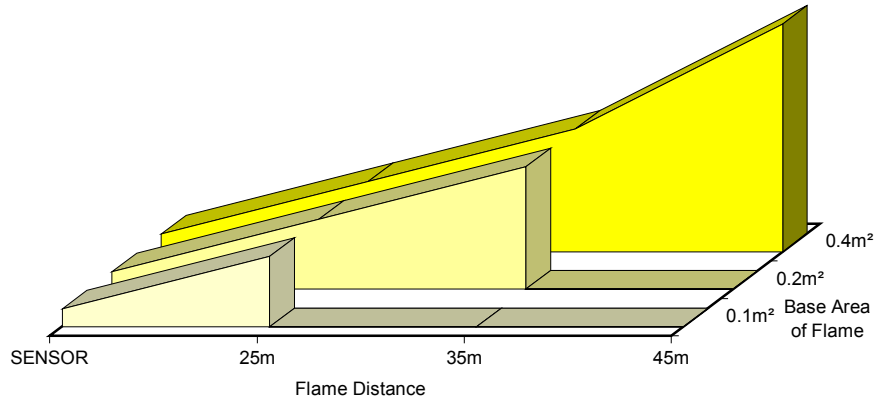

Fig. 2 Sensor centre line detection range for n-heptane fire (yellow sooty flame)
- UV / IR² Flame Sensor, sensitivity set high for class 1 performance

The polar diagram shows that the sensor sensitivity is at its greatest along the central axis. The variation in relative range against viewing angle is shown as a percentage of peak performance. The diagram is a section through the sensor's conical field of view. See Fig. 3

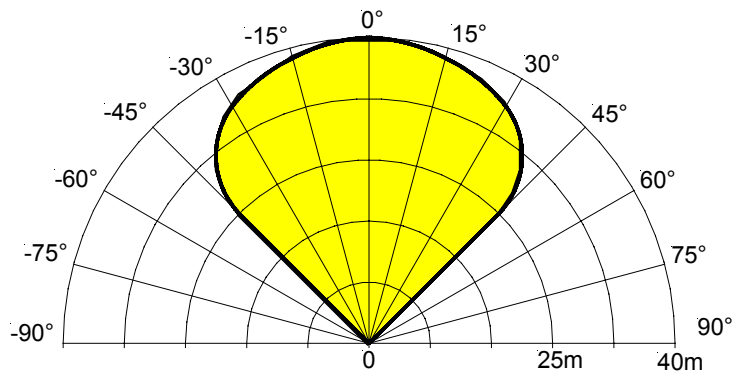

Fig. 3 Relative range as a function of viewing angle
- UV / IR² Flame Sensor

Alarm Current Output Values (Latching)

When the sensor detects a flame the sensor supply current value (4-20mA or 8-28mA) will increase.

The sensor is shipped with the internal DIL switch (5) set to give a latching alarm current. Normally the current required by the sensor is 4mA or 8mA at 24Vdc with no flame in view. When a flame is in view, the supply current value will increase to 20mA or 28mA, the fire relay RL1 will energise and red fire LED will illuminate.

The supply to the sensor has to be broken in order to reset the sensor.

Values below 3.0mA are an indication of a fault condition. See Fig. 4

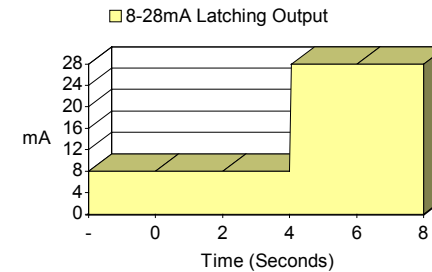

Fig. 4 Typical Response on seeing Flame
- UV/IR² Flame Sensor

Once illuminated the red Fire LED and output value are held for 5 seconds after the last flame has been seen, after which the output value decrements back to 4 or 8mA. See Fig. 6

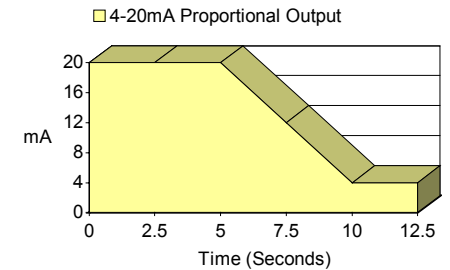

Fig. 6 Typical Response after last Flame seen
- UV/IR² Flame Sensor

Proportional Output Values (Non-latching)

When the sensor sees any flame flicker the proportional values of (4-20mA or 8-20mA) will increase.

The sensor is set to give a proportional value of 4mA or 8mA with no flame in view. The value increments when flame flicker pulses are seen.

With an output value approaching 20mA the fire LED will illuminate.

Values below 3.0mA are an indication of a fault condition. See Fig. 5

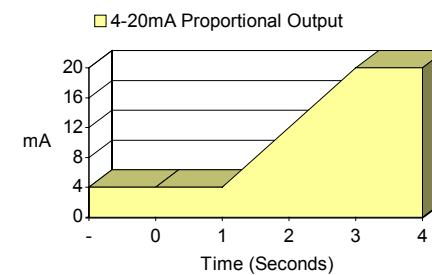

Fig. 5 Typical Response on seeing Flame
- UV/IR² Flame Sensor

Proportional output values between 4 or 8mA and 20mA can be used to provide an early warning of fire. These values hold only for 3 seconds from the last flame sighting. See Fig. 7

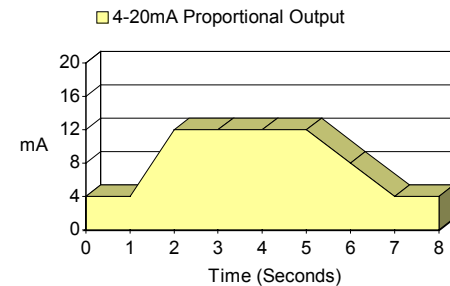

Fig. 7 Typical Response to Burst of Flame
- UV/IR² Flame Sensor